

Series BG350

adjustable inflatable header dock seal

BLUE GIANT®

Designed for 8' x 8' (2438mm x 2438mm) door openings, the BG350 series adjustable inflatable header dock seal employs a resilient vertical air bag construction to protect building walls and increase the contact area against the trailer.

Benefits

- SAVE hundreds of dollars in reduced energy costs
- IMPROVE working conditions by keeping dust, dirt, debris and insects out
- PROTECT product and personnel from harsh weather conditions
- INCREASE productivity by providing a safe and comfortable working environment
- DURABLE range of Hi-Performance fabrics to choose from
- CUSTOM sizes available



Standard Size Specifications

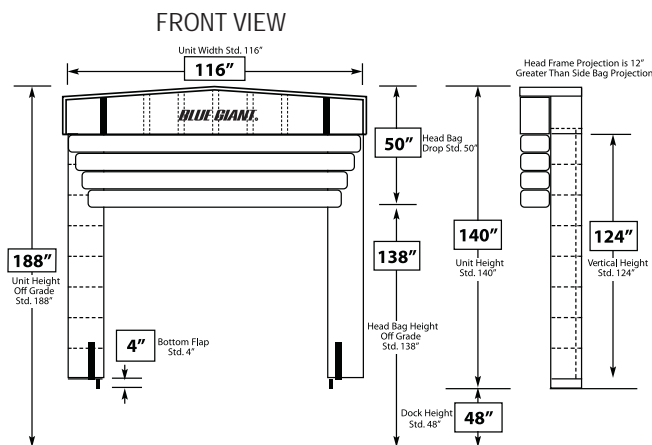

Generally designed to suit 8' wide x 8' (2438mm x 2438mm) high openings.

The BG350 series service a large variety of trailer heights. This unit minimizes pressure against the building wall from an incoming trailer as the unit is inflated after the trailer had docked.

A unique internal baffle system in the vertical air bags creates a square faced design that increases the contact area against the back of the trailer. An internal retraction spring allows the header air bag to be fully retracted when not in use to prevent damage from incoming trailers.

adjustable inflatable header dock seal

Blue Giant offers a wide variety of custom inflatables to satisfy your dock requirements.

- Square faced design creates larger contact area against truck
- Pressure treated non-rot wood framing
- 24" yellow guide stripes for accurate truck placement
- Translucent polyethylene sheeting on head frame allows light into dock area
- Internal retraction spring with external adjustment
- Custom sizes and projections available
- Available in 22oz Hi-Tear Vinyl or rugged 16oz Hi-Tear Hypalon

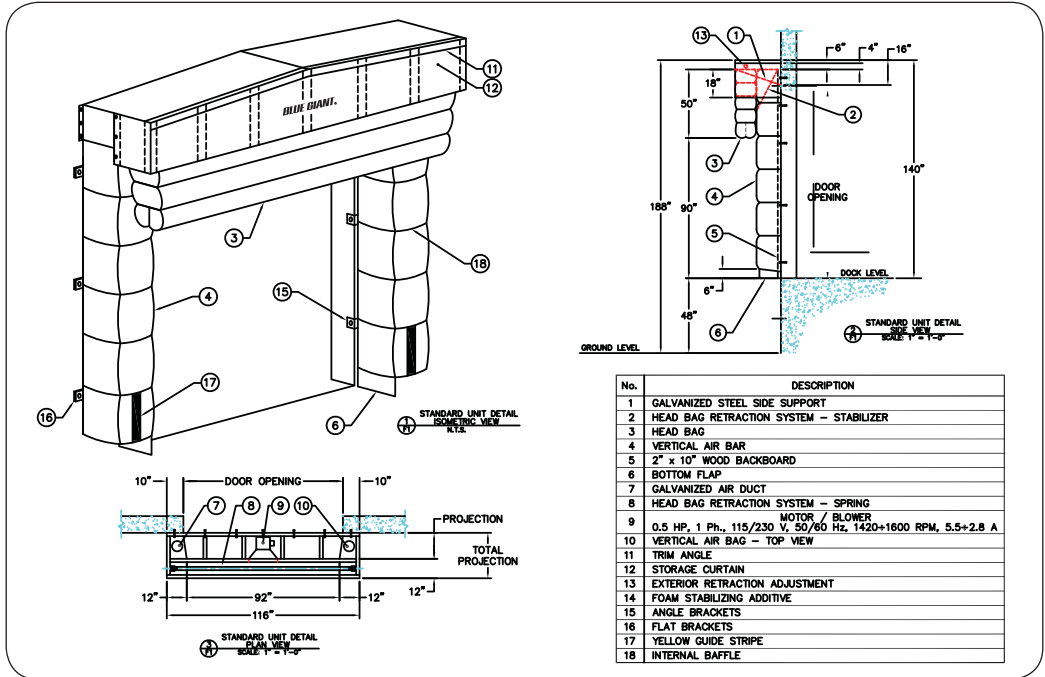

Customize Your Dock to Suit Your Specific Needs



INCLINE APPROACH



BEVELED AIR BAGS
(Top View)





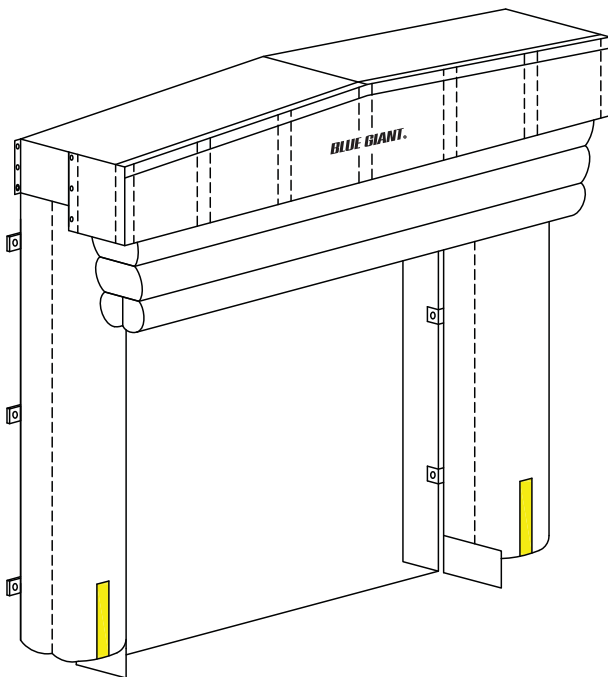

DECLINE APPROACH



Also available is the E350 with bubble design on header and sides.

Fabric and Colour Selection

Blue Giant can customize your dock seal with the ideal fabric for your application from a wide range of colours and fabrics available.

- 14oz Hi-Tear Vinyl 
- 22oz Hi-Tear Vinyl 
- 32oz Hi-Tear Vinyl 
- 40oz Hi-Tear Vinyl 
- Hi-Performance Arctic Seal 
- 16oz Hi-Tear Hypalon 
- 40oz Hi-Performance Hypalon 



85 Heart Lake Road South
Brampton, Ontario, Canada L6W 3K2
Phone: 905-457-3900 · Fax: 905-457-2313
www.BlueGiant.com

AUTHORIZED DISTRIBUTOR

BLUE GIANT EQUIPMENT CORPORATION

BLUE GIANT offers a full line of dock levelers, dock safety equipment, accessories, ergonomic and scissor lift equipment and industrial trucks. Concurrent with our continuing product improvement program, specifications are subject to change without notice. Please contact BLUE GIANT for latest information. Some features illustrated may be optional in certain market areas.