

Designed with the operator in mind, the 24 volt BGS Series straddle stacker offers maximum safety and operator comfort for all intermediate duty pallet handling applications.

CAPACITIES

- BGS-15 - 1,500 lb at 24" load center
- BGS-22 - 2,200 lb at 24" load center
- BGS-30 - 3,000 lb at 24" load center

LIFT HEIGHTS

- 52, 72 inches
- 90, 110, 130, 150 inches

OPERATION/CONTROLS

- Ergonomic design with butterfly toward/reverse travel controls
- Large safety reversing button propels truck away from operator and sounds horn if contact with operator is made
- Automatic "dead man" type braking with power cut-off switch when brake is applied
- Heavy duty motor, gear pump, check and relief valve
- Lifting and lowering functions feature "soft start - soft stop" electro-hydraulic acceleration and deceleration valving
- Overload pressure relief valve protects system from pressure overload and bypasses oil to reservoir when system reaches maximum pressure
- Piston style lift cylinder includes micro finished surface and high quality polyurethane seals

DRIVE SYSTEM

- Smooth, stepless, adjustable travel speeds and acceleration rate with controlled plug braking
- Programmable controller for energy saving motor and battery operation allows battery efficiency and usage to increase by up to 50% over conventional resistor type
- Diagnostic test and fault information
- Totally sealed gear reducer / brake system with internal multi disc brakes in oil bath that virtually eliminates conventional brake safety problems such as adjustments, drum and/or shoe replacement
- All gear and brake components protected from exposure to moisture and dirt, packaging, strapping etc.
- All gears are precision ground helical gears and drive axle mounted on precision tapered roller bearings
- 210 AH hours rating, (qty 4 - 12 volt 105 AH hours rating, minimum maintenance deep cycle) with removable tray
- 115/1/60 15 amp onboard charger with overload protection direct wired to batteries for error free charging

ELECTRICAL SYSTEM

- 24 volt
- Key switch
- Fused drive and control circuits
- Series wound high torque maintenance free drive motor, Class H insulation and heavy duty motor contactors with replaceable tips
- Solid state programmable speed controller with solid state throttle mechanism
- Emergency power disconnect button



FORKS/CHASSIS

- BGS-22/30 mast of I-beam design (nested on telescopic models) with high quality ball bearing rollers and carriage side thrust rollers
- Twin double strand leaf-style lifting chain
- 36" long forged forks
- Adjustable straddles to 50" ID with guarded tips to protect wheels
- Safety screening protects operator from lifting mechanisms and provides maintenance free visibility

WHEELS

- Press-on 10" x 4" white, non-marking rubber, taper mounted hub design for easy servicing
- Poly straddle wheels 4" x 2" with precision sealed ball bearings

OPTIONAL EQUIPMENT

- Special application tires
- Other fork sizes
- Battery gauges
- U.L EE rating

Specifications

| | | BLUE GIANT | | | |
|---------------------------|--------------------|-------------------------------------|----------------------------|----------------------------------|---------|
| CHARACTERISTICS | Manufacturer | (Abbreviation / Symbol) | | | |
| | Model | Manufacturer's designation | | | |
| | Capacity | Q | Rated capacity | 1,500 lb 2,200 lb 3,000 lb | |
| | Load center | C | Distance (Refer to charts) | 24" | |
| | Power type | Electrical | | | |
| | Control type | Hand, Pedestrian, Ride-On | | | |
| | Tire equipment | Drive end / Load end | | | |
| | Wheels | Number(x=driven) Drive end/Loadend | | | |
| DIMENSIONS | Lift | H3 Lift | Refer to charts | | |
| | | Lift and fork height | Refer to charts | | |
| | Forks | H2 Free lift | 24" | 12" | 12" |
| | | S Forks lowered | 2" | 2.5" | 2.5" |
| | | I Length standard | 36" | | |
| | | Length optional | 42", 48" | | |
| | | B3 Fork adjustment | 8.5"- 27.25" | | |
| | Overall dimensions | E Fork width x Thickness | 4" x 1.5" | | |
| | | L Length | 71.5" | | |
| | | B Straddle I.D. Standard / Optional | 41" to 50" / 31" to 40" | | |
| | | H1 Minimum straddle I.D. setting | Refer to charts | | |
| | | H4 Lowered mast height | Refer to charts | | |
| Turning radius | WA | 60.5" | | | |
| | 90° Stacking aisle | Refer to charts | | | |
| PERFORMANCE | Speeds | Traveling - with load | 2.9 mph | 2.6 mph | 2.5 mph |
| | | Traveling - without load | 3.1 mph | | |
| | | Lifting - with load | 22 fpm | 16 fpm | 15 fpm |
| | | Lifting - without load | 35 fpm | 25 fpm | 23 fpm |
| | | Lowering - with load | 42 fpm | 37 fpm | 36 fpm |
| | | Lowering - without load | 22 fpm | 19 fpm | 15 fpm |
| Grade clearance | 8% | | | | |
| LOAD | Dead weight | Including battery | | | |
| | Axle loading | Loaded - drive end | 40% | 33% | 28% |
| CHASSIS | Tires | Quantity - Drive end / Load end | 1 / 2 | | |
| | | Dia. x width - Drive end | 10" x 4" | | |
| | | Dia. x width - Load end | 4" x 2" | | |
| | Wheel base | Y | Distance between wheels | 51.5" | |
| | Ground clearance | 1.25" | | | |
| | Track | Center of tires | | | |
| | Service brake | Straddle I.D. + 3" | | | |
| POWER / DRIVE UNIT | Battery | Type | Wet | | |
| | | Voltage / AH | 24 / 170 | | |
| Electric motors | Drive control | Battery compartment L x W x H | 28.6" x 9" x 24.6" | | |
| | | Drive motor | 1 hp | | |
| Transmission | Type | Lift motor | 5 hp | | |
| | | Type | Solid state | | |
| | | Stages forward / reverse | Variable | | |
| | Type | Geared | | | |

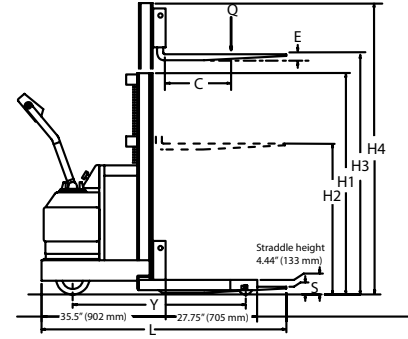

MAST SPECIFICATIONS

| MODEL | LIFT | FREE LIFT | STAGES | MINIMUM STRADDLE I.D. | LOWERED MAST HEIGHT | RAISED MAST HEIGHT |
|-----------|--------|-----------|--------|-----------------------|---------------------|--------------------|
| — | H3 | H2 | — | H1 | H4 | H5 |
| BGS-15 | 52" | 52" | 1 | 31" | 72" | 72" |
| BGS-22/30 | 52" | 52" | 1 | 31" | 71.25" | 71.25" |
| BGS-15 | 72" | 72" | 1 | 31" | 92" | 92" |
| BGS-22/30 | 72" | 72" | 1 | 31" | 91.25" | 91.25" |
| BGS-15 | 90" | 23" | 2 | 31" | 72" | 108.75" |
| BGS-22/30 | 90" | 11" | 2 | 31" | 65.25" | 109" |
| BGS-15 | 110" | 23" | 2 | 31" | 82" | 128.75" |
| BGS-22/30 | 110" | 11" | 2 | 31" | 75.25" | 129" |
| BGS-15 | 130" | 23" | 2 | 33" | 92" | 148.75" |
| BGS-22/30 | 130" | 11" | 2 | 33" | 85.25" | 149" |
| BGS-15 | 150" | 23" | 2 | 38" | 102" | 168.75" |
| BGS-22/30 | 150" * | 11" | 2 | 38" | 95.25" | 169" |

* 3,000 lb model, downrated to 2,200 lb capacity above 130" lift

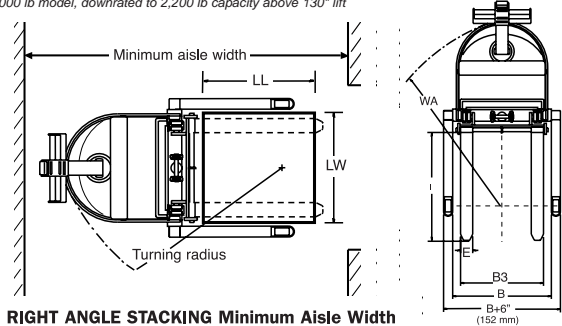

RIGHT ANGLE STACKING Minimum Aisle Width

1) If pallet bay opening is load width plus 10"

| LOAD WIDTH (LW) | LOAD LENGTH (LL) | | | |
|-----------------|------------------|-----|-----|-----|
| | 30" | 36" | 42" | 48" |
| 30" | 72" | 72" | 72" | 72" |
| 36" | 73" | 73" | 73" | 73" |
| 42" | 75" | 75" | 75" | 75" |
| 48" | 76" | 76" | 76" | 76" |

2) If pallet bay opening is load width plus 4" - 6"

| | | | | |
|-----|-----|-----|-----|-----|
| 30" | 72" | 77" | 85" | 93" |
| 36" | 73" | 79" | 87" | 94" |
| 42" | 74" | 80" | 88" | 95" |
| 48" | 76" | 81" | 89" | 97" |



85 Heart Lake Road South
 Brampton, Ontario, Canada L6W 3K2
 Phone: 905-457-3900 • Fax: 905-457-2313
 www.BlueGiant.com

AUTHORIZED DISTRIBUTOR

BLUE GIANT EQUIPMENT CORPORATION

BLUE GIANT offers a full line of Loading Dock Equipment including Dock Levelers, Vehicle Restraints, Dock Seals and Shelters an improvement program, specifications are subject to change without notice. Please contact BLUE GIANT for latest information. Some

Material Handling Solutions. Concurrent with our continuing product e features illustrated may be optional in certain market areas.