

INSTALLATION & OWNER'S MANUAL

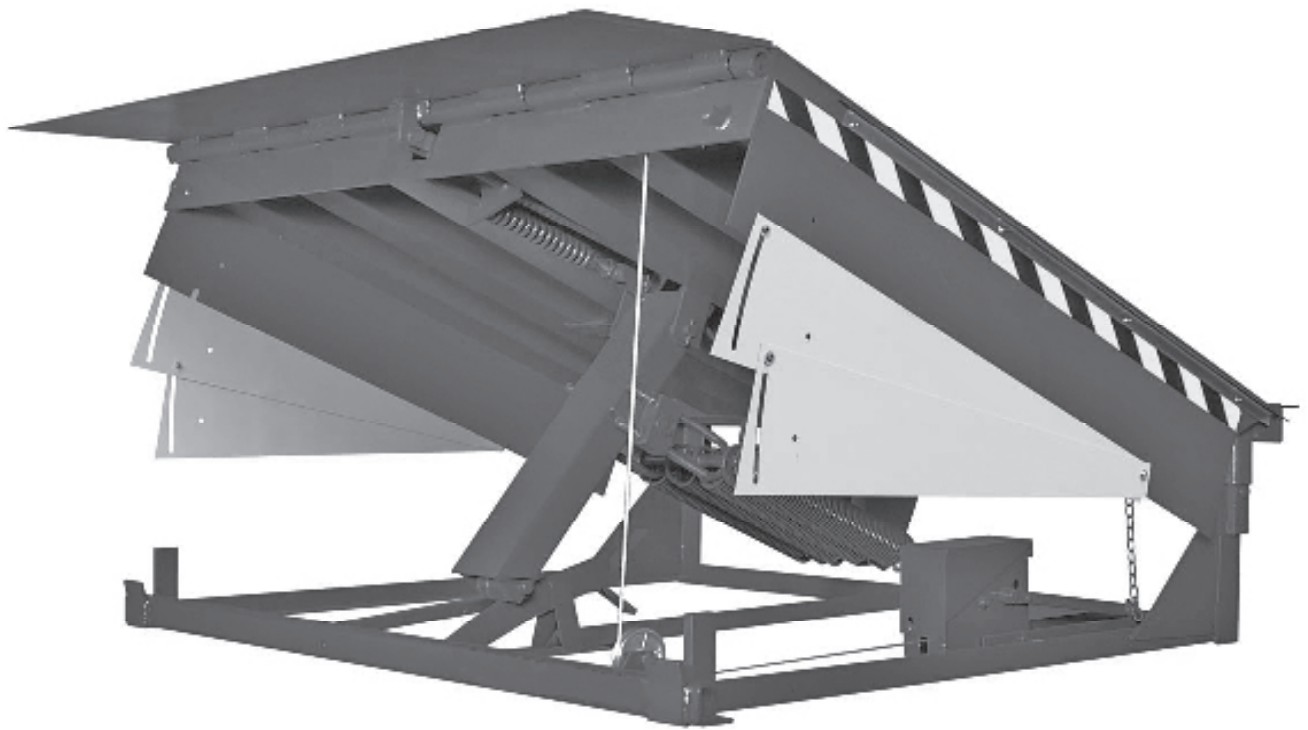

⚠ WARNING

DO NOT INSTALL, OPERATE OR SERVICE THIS PRODUCT UNLESS YOU HAVE READ AND FULLY UNDERSTOOD THE ENTIRE CONTENTS OF THIS MANUAL. FAILURE TO DO SO MAY RESULT IN PROPERTY DAMAGE, BODILY INJURY OR DEATH.

SAFETY PROCEDURES

INTRODUCTION

The following is intended to be a quick reference to some of the important procedures to follow while using the C Series Model FMC Dock Leveler. It is not intended to cover, or suggest that it does cover, all procedures required to be followed to ensure safe operation. Operators should be aware of and abide by all workplace safety regulations that may apply to the operation of the C Series Model FMC Dock Leveler. These laws and regulations include but are not limited to:

- Occupational Safety and Health Act (USA).
- Occupational Safety and Health Acts for Individual States (USA).
- Canadian Material Handling Regulations.

For further information on these regulations and / or industry standards that may apply to this equipment, please contact:

American National Standards Institute (ANSI)
1430 Broadway
New York, NY 10018
(212) 642-4900

WARNING

- 1. Untrained personnel shall not be allowed to install, operate and/or service mechanical dock leveler.**
- 2. Do not install this leveler, operate and/or service unless you have been trained and authorized to do so.**
- 3. Do not install, operate and/or service this leveler until you have read and understood all of the safety information and instructions contained herein and on the leveler.**
- 4. Do not operate this leveler until you have checked its condition. Report the need for leveler repairs to your supervisor immediately and do not operate leveler until repairs are made. Neglect may cause a minor repair to become a major service problem and cause the leveler to become unsafe.**
- 5. Do not work under or around leveler being installed without first placing adequate barriers to positively prevent vehicle traffic from entering the work area.**
- 6. All electrical wiring, hook-up, repair and troubleshooting must be performed by a qualified service personnel. All wiring, hook-up and repairs must be made to meet all applicable codes. Before doing any electrical work, make certain the power is disconnected and properly tagged and / or locked out.**
- 7. Before performing any maintenance, secure maintenance strut in place.**
- 8. Do not load leveler beyond capacity shown on serial name plate on leveler.**
- 9. Stay clear of dock leveler and truck when truck is backing in or leaving dock area.**
- 10. Secure Truck by chocking truck wheels or use of vehicle restraint, as detailed by OSHA, before operating dock leveler.**
- 11. Do not use or move the dock leveler if anyone is under, in front and/or on dock leveler.**

- 12. Keep hands and feet clear of dock leveler pinch points at all times. Never use hands to lift dock ramp and/or lip onto truck or to store dock leveler.**
- 13. Never try to lift or move any part of the Dock Leveler without using the Release Chain.**
- 14. Do not drive on leveler unless lip is securely on truck bed and has a minimum of 4" (100mm) projection on truck bed.**
- 15. Do not exceed 4 mph when driving over dock leveler.**
- 16. Do not drive over edges of the leveler and / or dock bumper blocks (bumpers S/B bumperblocks are not structural).**
- 17. Do not leave equipment or material unattended on leveler.**
- 18. Do not leave the leveler unattended in the deployed position.**
- 19. Do not use fork truck or any other material handling equipment to lower leveler ramp.**
- 20. Never attempt to perform repairs. Always defer repairs to a qualified service technician.**
- 21. Do wear safety equipment as required.**
- 22. Do not mix drugs or alcohol with your job.**

This manual is intended to be readily available. Keep it near the leveler as a ready reference for anyone who may operate or service it. If the leveler being operated is not equipped with a manual, request to obtain one and have it located near the leveler.

An authorized dealer or distributor is readily available to answer questions about leveler operation and maintenance and will provide additional information should it be required.

EXCLUSION OF LIABILITY

The manufacturer assumes no liability for damage or injury to persons or property which have occurred as a result of defects or faults in the dock levelers delivered or due to incorrect use. The manufacturer also assumes no liability for lost profits, operating down times, or similar indirect losses which the buyer has incurred. Damage to third parties, irrespective of its nature, is not subject to compensation.

The operating instructions are not subject to notification of amendment. The descriptions and illustrations included in our operating instructions and replacement parts list are not binding. In the interests of continuing product development, we reserve the right to make any changes at any time to the modules, components and accessories, concurrent with our continuing product improvement program, specifications are subject to change without notice. Please contact manufacturer for latest information.

SAFETY WARNINGS

Safety Signs and Safety Messages

Improper operation can cause accidents. Don't take chances with incorrect or damaged equipment. Read and understand the procedures for safe operation and maintenance outlined in this manual. Don't hesitate to ask for help.

Stay alert! Follow safety rules, regulations, and procedures. Avoid accidents by recognizing dangerous procedures or situations before they occur.

Safety signs and messages are placed in this manual to provide instructions and identify specific areas where potential hazards exist and special precautions should be taken. Know and understand the meaning of these instructions, signs, and messages. Damage to the equipment, death, or serious injury to you or other persons may result if these messages are not followed. If warning decals are damaged, they must be replaced. Contact your Distributor for replacements.

DANGER

This message indicates an imminently hazardous situation which, if not avoided, will result in death or serious injury

WARNING

This message indicates a potentially hazardous situation which, if not avoided, could result in death or serious injury.

CAUTION

This message indicates a potentially hazardous situation which, if not avoided, may result in minor or moderate injury

IMPORTANT

This message is used when special precautions should be taken to ensure a correct action or to avoid damage to or malfunction of the Dock Leveler or a component.

TABLE OF CONTENTS

Safety.....	1-2
Table of Contents.....	3
Owner’s Record of Purchase.....	3
Check Shipment Notice.....	3
Installation Instructions.....	4-6
Operating Instructions.....	7-8
Maintenance.....	9-10
Dock Leveler Components Diagram.....	11
Trouble Shooting.....	12
General Assembly Diagram & Parts - 25,000 lb, 30,000 lb & 35,000 lb Capacity.....	13-16
Holdown Assembly Diagram & Parts.....	17-18
Safety Skirts Assembly Diagram & Parts.....	19
Warranty.....	20

CHECK SHIPMENT BEFORE INSTALLATION

The leveler has been carefully checked at the manufacturer’s plant before shipment. In order to ensure that no damage has occurred during transport, the dock leveler should be checked upon receipt for transport damage and to ensure correct operation. Damage due to transport is to be listed on the signed copy on the freight document. The freight forwarder must be notified of any damage within 48 hours. Damaged dock levelers must not be put into use.

OWNER’S PURCHASE RECORD	
Dealer:	Date in Service:
Owner:	Number of Units:
Order Number:	Year of Construction:
Serial Number(s):	

The manufacturer offers a full line of dock levelers, dock safety equipment, accessories, ergonomic and scissor lift equipment, and industrial trucks. Concurrent with our continuing product improvement program, specifications are subject to change without notice. Please contact manufacturer for latest information. Some features illustrated may be optional in certain market areas.

INSTALLATION INSTRUCTIONS

WARNING

Use caution when lifting or moving the leveler. Do not attempt to lift without suitable hoisting equipment capable of lifting as much as 3500 lbs.

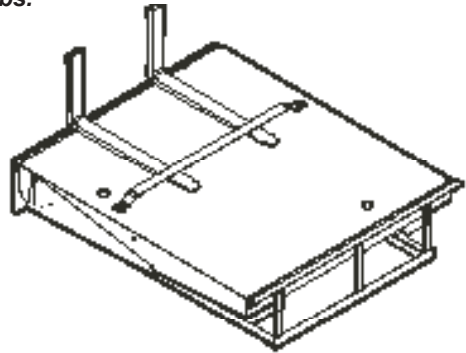

FORK LIFT TRUCK HANDLING

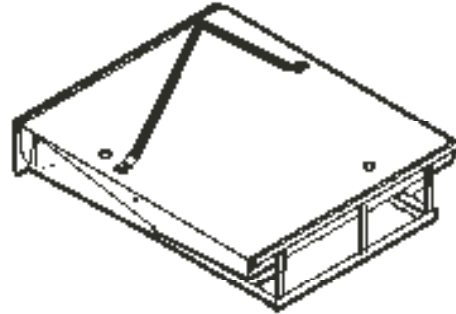

SLING HANDLING

STITCH WELD

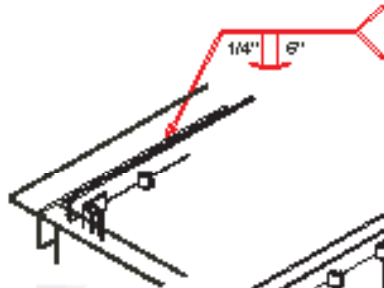

SHIM BOTH SIDES
5" X 5" - 127 mm x 127 mm

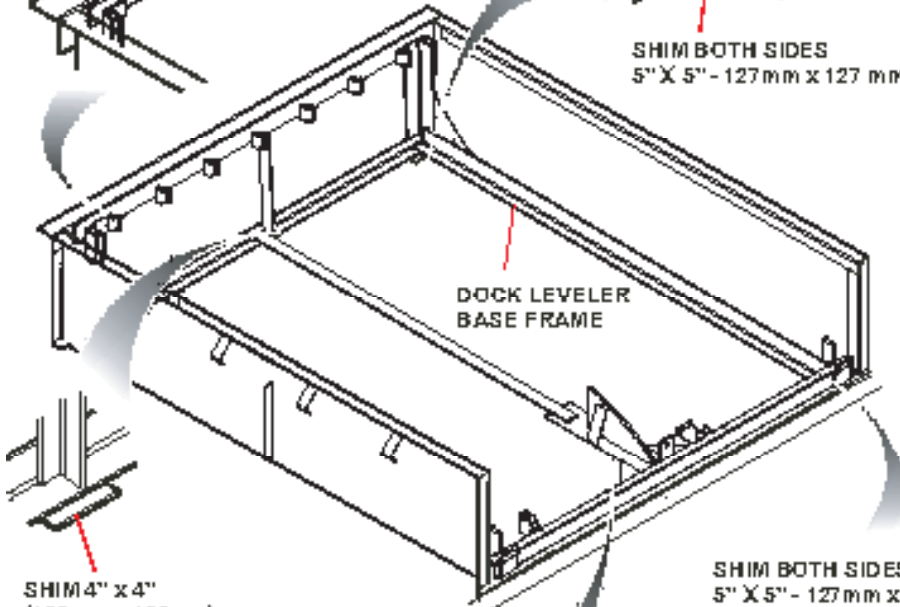

SHIM 4" x 4"
{102 mm x 102 mm}



SHIM BOTH SIDES
5" X 5" - 127 mm x 127 mm

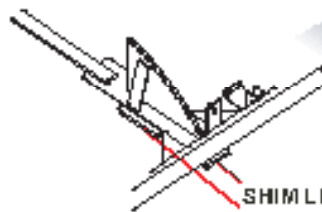

SHIM LIFT ARM
BASE BRACKET
5" X 5" - 127 mm x 127 mm

Figure 1 : Dock Leveler Installation Pictorial

INSTALLATION INSTRUCTIONS

WARNING

Do not install, operate and/or service this leveler until you have read and understood all of the safety information and instructions contained herein and on the leveler.

Do not work under or around leveler being installed without first placing adequate barriers to positively prevent vehicle traffic from entering the work area.

Keep hands and feet clear of dock leveler pinch points

IMPORTANT

The following information is essential for proper installation

Pit Curb Angles

- A. Must be level side-to-side and front-to-back.
- B. Must be square at both rear corners.
- C. Side curb angles must be parallel to each other.
- D. Finished floor to be flush with top surface of curb angle.

The leveler must be welded to a firmly embedded steel or other dock steel as described in the installation instructions. Do not attempt to use only bolts or anchors, to attach the dock leveler to the concrete.

1. Prior to installation, clean pit thoroughly and verify that all dimensions are in accordance with Blue Giant specifications.

2. Measure height of rear corners of dock leveler, bottom of frame to top of deck plate, typically 19" or 23"(485 or 585mm). Measure depth of pit at both rear corners where rear bottom corners of frame will be positioned. Locate and place suitable shims (not supplied) in pit corners to produce a depth to match frame height. See Figure 2, Page 3.

3. Measure height of front corners of dock leveler, bottom of frame to top of deck plate, typically 19-1/2" or 23-1/2" (495 or 595mm). Measure depth of pit at both front corners where front bottom corners of frame will be positioned. Locate and place suitable shims (not supplied) at both front corners to produce a depth to match frame height. See Figure 2, Page 3.

WARNING

Use caution when lifting or moving the leveler. Do not attempt to lift without suitable hoisting equipment capable of lifting as much as 3500 lbs.

Do not work beneath a raised object. Follow all hoisting safety requirements.

4. Using extreme caution, sling dock leveler into place squarely above pit and lower gently onto pre-located shims. Locate and square dock leveler to best suit pit and dock face. Space between sides of deck and sides of pit should be equal. See Figure 2 Page 5.

WARNING

Use caution when unbanding the leveler. Keep hands clear of pinch points and wear appropriate safety attire - glasses, gloves and work boots. Note: There is the potential for the dock leveler to deploy when the shipping bolt is removed. The hold-down mechanism must be engaged prior to removal of shipping bolt.

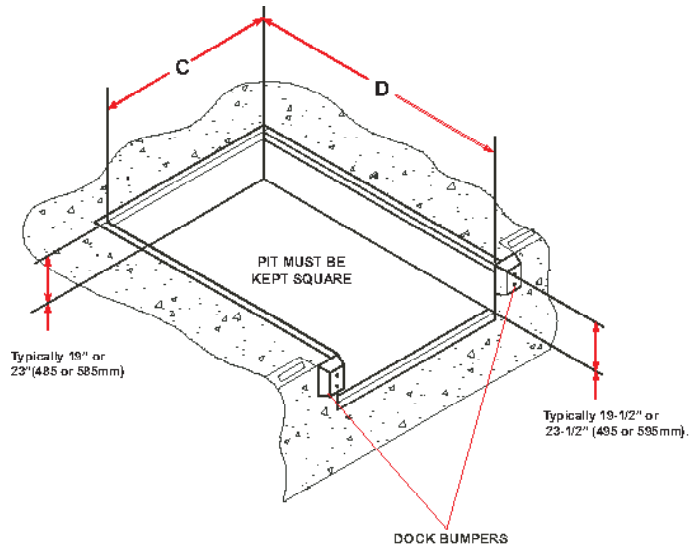

Figure 2 : Pit Layout - Typical

5. Remove sling brackets, chains, etc. from the deck. Remove and discard the shipping bolt from the front of the dock leveler lip plate.

WARNING

Do not work beneath dock leveler without engaging maintenance strut.

6. If rear beam does not line up squarely with rear curb angle, use 3" x 6" (75mm x 150mm) shims of suitable thickness to fully support top rear and bottom rear of rear beam at weld areas. Weld rear beam to curb steel with 1/4" x 6" (6mm x 150mm) welds, on 9-5/8" (250mm) centers. See Figure 1, Page 2.

IMPORTANT

It is important that these shims fill space between bottom edge of back beam and face of curb angle as well as top edge, behind each hinge lug. Assure the top of the back beam is flush with the top surface of rear curb angle and finish weld back beam to curb angle as detailed in Figure 1, Page 2.

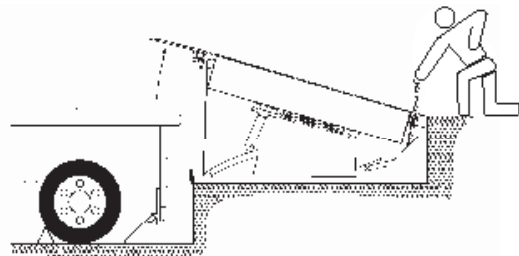

7. Partially operate the Dock Leveler by pulling firmly upward on the hold down release ring (located in the right rear corner of the deck surface) and quickly releasing it so that the deck rises approximately 4" – 6".

INSTALLATION INSTRUCTIONS

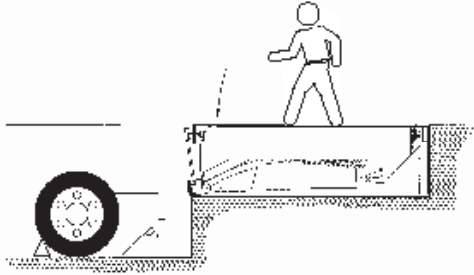

8. Lower the deck back to its stored position by walking up the slope of the deck. Ensure the deck is fully down to stowed position with the tip of lip plate located inside the lip keepers.
9. Check that all four corners of the dock are square and flush to the floor level. Make note of areas where shims need to be added or removed.
10. Adjust the height of all front shims as required to level the front sides of the deck with the pit side curb angles.
11. Tack-weld the front shims together.
12. Tack-weld the welded front shims to the front of the Dock Leveler frame.
13. Tack-weld the welded front shims to the front pit curb angle.
14. Repeat this process for the rear frame parts and shims. To do this, the deck must be raised again and a maintenance strut put in place.

WARNING

Do not work beneath dock leveler without engaging maintenance strut.

15. Firmly pull up on the hold down release chain and hold it to raise the deck to full height and extend the lip plate.
16. Quickly place the maintenance strut in its vertical position before the lip plate folds in to its pendant position.

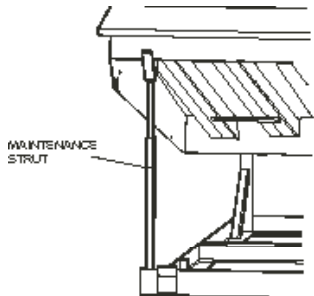

17. Remove pin from telescopic maintenance strut, extend the maintenance strut to the desired height, reinsert pin and walk the deck down to engage the maintenance strut.
18. Tack-weld the rear shims together.
19. Tack-weld the welded rear shims to the rear Dock Leveler frame. Finish weld all shims, Refer to Figure 1 : Dock Leveler Installation Pictorial.
20. Finish weld all rear shims together.
21. Finish weld all rear shims to rear Dock Leveler frame.
22. Finish weld all front frame shims together.
23. Finish weld front frame shims securely to the front frame.
24. Finish weld front frame shims securely to the front pit curb angle.

STITCH WELD

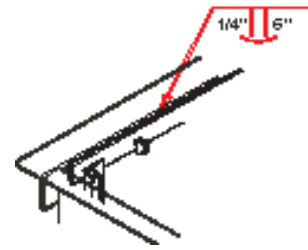

25. Finish weld the upper dock leveler rear frame to the upper rear pit curb angle. Stitch weld centered on and opposite to rear frame hinge spools.
26. Install specified dock bumpers as required.

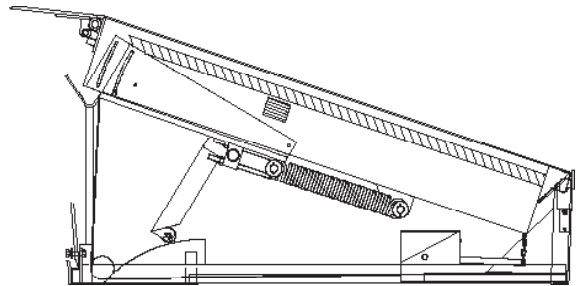

27. Remove the shipping lock bolt and nut from front end of sliding side safety skirts (if equipped) and allow front ends to swing down to working position.
28. Mount "Operating Hazards DANGER" placard, provided with these Instructions to the wall in plain view of dock leveler operations.
29. Mount No. 2 envelope containing Owner / Operator Manual and Warranty Validation Form to be returned to the manufacturer.
30. Perform a final inspection and determine that all work is completed satisfactorily. Clean pit and work area thoroughly and apply touch-up paint to weld burn areas, scratches, etc.
31. Test operate the unit through several full cycles of all functions.

Refer to Owner's Manual for Operating Procedures.

If adjustments are required, refer to Troubleshooting

Installation Inspection

1. Clean up the entire work area and apply touch-up paint to all welds, scratches and burns.
2. Ensure all concrete wedge anchors have been securely tightened.

WARNING

Read and understand this entire manual prior to operating.

3. Test operate the unit through several full cycles of operation. Refer to: Operating Procedures. If problems are noted, See Section on Troubleshooting.
4. Leave these Instructions with the Dock Leveler for use by owner.

OPERATING INSTRUCTIONS

⚠ WARNING

Do not install this leveler, operate and/or service unless you have been trained and authorized to do so. Do not install, operate and/or service this leveler until you have read and understood all of the safety information and instructions contained herein and on the leveler.

Do not operate the dock leveler beyond its rated capacity.

Do not operate this leveler until you have checked its condition. Report the need for leveler repairs to your supervisor immediately and do not operate leveler until repairs are made. Neglect may cause a minor repair to become a major service problem and cause the leveler to become unsafe.

Never try to lift or move any part of the Dock Leveler without using the Release Chain Ring.

Keep hands and feet clear of dock leveler pinch points at all times. Never use hands to lift dock ramp and/or lip onto truck or to store dock leveler.

Do not drive on leveler unless lip is securely on truck bed and has a minimum of 4" (100mm) projection on truck bed.

Do not exceed 4 mph when driving over dock leveler. Do not drive over edges of the leveler and / or dock bumper blocks (bumpers blocks are not structural).

FUNCTIONAL DESCRIPTION

The Dock Leveler is intended to be used as a bridge located between a loading dock floor surface and the truck bed.

The Dock Leveler upper deck plate complete with a hinged, vertically hanging lip plate is located flush with the floor surface and the edge of the dock, in a shallow pit.

The trailer and the truck are parked and blocked in place against the outer wall of the loading dock, in working alignment with the Dock Leveler. A Dock Leveler in combination with a Vehicle Restraint are ideal for this application. Consult your local Dealer/Distributor.

The Dock Leveler is operated allowing tensioned springs to raise the front of the Deck. The hinged lip plate raises with the deck and it's leading edge swings out horizontally over the rear of the truck bed, as the deck reaches its fully raised position.

The Dock Leveler operator walks up the sloped deck and his/her body weight causes the deck and the extended lip to lower together until the underside of the extended lip makes contact on the bed of the truck.

A bridge is now formed that is supported at the building end by the dock floor and at the vehicle end by the truck's bed.

No other means of support is provided when in this position.

During loading / unloading operations, the deck and lip automatically follow the raising and lowering movement of the truck.

The Dock Leveler is returned to its original stored position by the Dock Leveler operator. In the stored position, both ends of the Dock Leveler upper deck plate are supported. The building end is supported by the dock floor and the vehicle end is supported by the lip, lip keepers, and the pit floor.

Operating Procedure

⚠ WARNING

Secure the truck with a vehicle restraint, wheel chocks or other method before commencing traffic across the dock leveler.

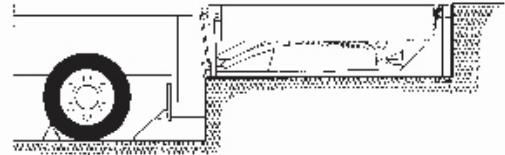

1. In the stored position, the lift springs are stretched and the lifting arm is at the base of the cam.

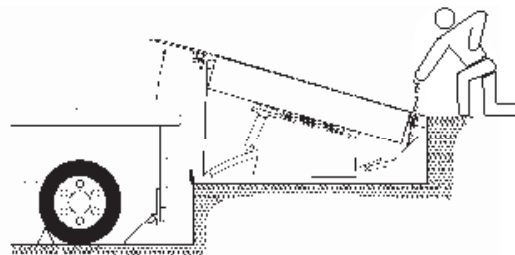

IMPORTANT

Releasing the hold down release ring will stop the upward travel of the dock.

2. To raise the dock leveler, the Hold Down release ring is pulled firmly up and held. As the deck rises, the lip plate will extend

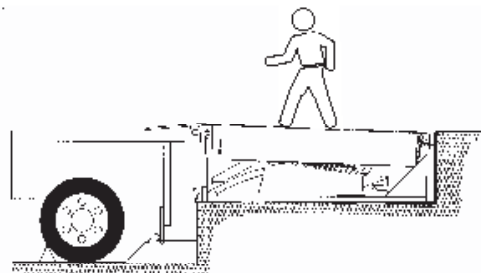

3. Once the deck is in the raised position, the operator walks the deck down to the loading / unloading position.



4. The loading/unloading operation is performed and completed.

OPERATING INSTRUCTIONS

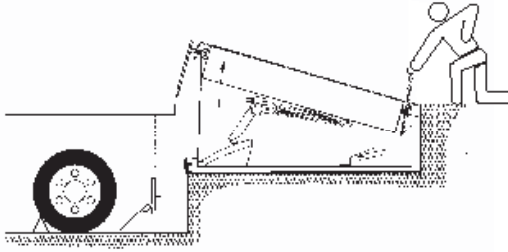

5. To return the deck to the stored position, the Hold Down release ring is pulled and held just long enough for the lip plate to clear the trucks loading bed. After the lip plate has dropped to the pendant position, the operator can then began to walk down the deck.

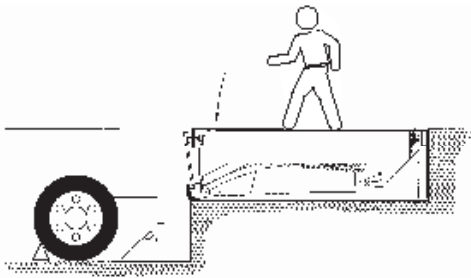

6. The operator walks down the deck until it reaches the stored position, ensuring that the lip is located inside the lip keepers

WARNING

The truck should never be allowed to depart with the lip plate resting on the loadedbed.

7. The operator releases the vehicle restraint or removes the wheel chocks to allow the truck to depart. The operator then indicates to the truck driver that it is safe to depart.

Below Dock Level Control: End Loading

Refer also to Mechanical Fall Safe and Below Level Control Operation

This section describes operation of a dock leveler in situations where contact of the dock leveler lip plate with the vehicle load bed is not possible (e.g. loading/unloading the first skid or pallet from the vehicle load bed where there is insufficient surface area to extend the dock leveler lip plate.)

The Dock Leveler deck is raised by firmly pulling up the Hold Down release ring in the right rear corner of the deck and holding until the deck rises to full height. The operator then releases the Hold Down release ring and walks down the deck. The deck is lowered by the operators weight as he walks up its slope. The operator must properly time the walk down such that the dock leveler lip plate folds in enough to miss the vehicle load bed, but not enough for it to engage the lip keepers.

The lip plate is allowed to remain in the pendant position and is allowed to slip in between the rear of the transporter vehicle load bed and the building foundation without engaging the lip keepers. When unloading a truck and the first skid or pallet has been removed, the dock leveler must be reset with the lip plate in the extended position. When the lip makes firm contact with the vehicle load bed, the unit is ready for traffic

Mechanical Fall Safe and Below Level Control Operation

The Mechanical Fall Safe Option consists of two Support Legs that are held rigidly in a vertical position by springs to arrest downward travel of the deck by approximately 2-1/2" (60mm) below level position.

In situations where the deck needs to be operated below cross-traffic position by more than 2-1/2", the Fall Safe Support Legs need to be retracted by using the Control Activator located at the left front corner of the deck. The Control Activator pull ring retracts the Support Legs to allow the dock leveler to travel a full 12" below level position. The Support Legs will return to the normal pendant position when the Control Activator ring is released and the deck is raised high enough by operation of the Hold Down release ring.

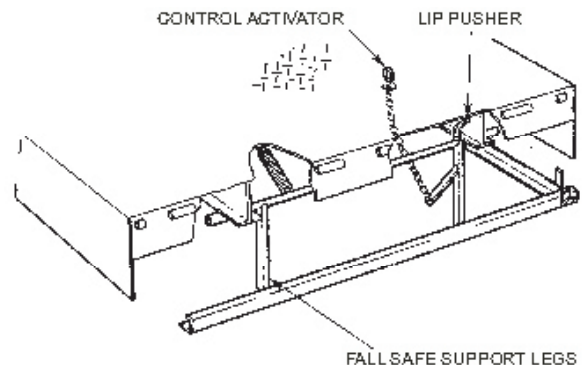

The loading/unloading operation is performed and completed.

Follow Steps 5 and 6 of Operational Procedures to store dock. If further loading/unloading required follow Safety and Operational Procedures to resume normal operation.

MAINTENANCE

Planned Maintenance

In addition to the daily operator inspection, the manufacturer recommends and local Government regulations may require that a planned maintenance (PM) and safety inspection program be performed by a trained and authorized service technician on a regular basis to maintain the equipment in safe operating condition. The PM will provide an opportunity to make a thorough inspection of the safety and operating condition of the Dock Leveler. Necessary adjustments and repairs can be done during the PM, which will increase the life of components and reduce unscheduled downtime and increase safety. The PM can be scheduled to meet any particular application and Dock Leveler usage.

The procedures for a periodic planned maintenance program that covers inspections, operational checks, cleaning, lubrication, and minor adjustments are outlined in this manual. An authorized dealer or distributor is prepared to assist with a Planned Maintenance Program by trained service personnel who possess expertise in Dock Leveler safety and efficiency.

Operator Daily Inspection

The Dock Leveler should always be examined by the

operator to ensure it is safe to operate, **PRIOR TO ANY USE**. The importance of this procedure is emphasized in this manual with a brief illustrated review and later with more detailed instructions. The manufacturer recommends making multiple photocopies of Operator's Daily Checklist. The operator should make a daily inspection prior to use; filling out this form in order to keep a daily record of operation and maintenance issues.

Routine Servicing And Maintenance

Regular maintenance and care of the Dock Leveler is very important for cost and operation efficiency and more importantly; operator safety. A faulty Dock Leveler is a potential source of danger to the operator, and to other personnel working near it. As with all quality equipment, keep the Dock Leveler in good operating condition by following the recommended schedule of maintenance.

Failure to properly maintain or operate the dock leveler within its rated capacity can void the manufacturer warranty.

Complete the Warranty Validation Form provided with this manual and return it to factory.

	EXTENSION SPRINGS	DECK ASSEMBLY	SAFETY LEGS	LIP HINGE ASSEMBLY	LIP EXTENSION SYSTEM	HOLDOWN ASSEMBLY
INSPECT	ALL THE ABOVE EVERY 90 DAYS					
CLEAN	ALL THE ABOVE EVERY 90 DAYS (Lip Clean As Required)					
LUBRICATE	As Needed	Every 90 Days Pivot Points (Light Oil)	Every 90 Days (Light Oil)	Every 90 Days (Grease)	Every 90 Days (Light Oil)	Not Required
ADJUST	As Needed	Not Required	Not Required	Not Required	As Needed	As Needed

PM CHECK LIST - DOCK EQUIPMENT

Customer		Tel		SWO#	
Location		Cust. Contact			
Date		Inspected By			
CLEAN	Repairs?	OK	CHECK / ADJUST / LUBE	Repairs?	OK
Pit Area			Contactors Tips		
Deck Hinge			Electrical Connectors		
Lip Hinge			Hydraulic Connectors		
			Fasteners		
CHECK	Repairs?	OK	Lip Actuating Cables		
			Shock Cable		
Guard Rails / Pockets			Cylinder Stop Cable		
Control			Relief Valve - Below Level		
Wire Harness			Lowering Speed Flow Control		
Hose Assembly			Hydraulic Oil Level Condition		
Cylinder Packings			Bypass At Stops		
Actuating Cables			Lift Spring Tension		
Actuating Springs			Lift Chain Adjustments		
Structural Damage			Cable Clamp Tension		
Full Operating Cycle			Lip Hinge / Lip Chains		
Dock Bumpers / Extensions			Shock Absorber Pivot		
Overhead Door			Lip Actuating Pivots		
Curb Angle			Lifting Arm Pivots		
Installation / Structural Welds			Cable Rollers		
Safety Skirts / Encloser			Crossheads		
Safety Trip Bars			Lifting Chains		
Hold Down Box			Leg Rollers		
Chain Wear			Scissor Pin Bushings		
Cotter Pin Wear			Cradle Wear Plates		
COMMENTS					
REPAIRS RECOMMENDED					

⚠ WARNING

Do not install this leveler, operate and/or service unless you have been trained and authorized to do so.

MECHANICAL DOCK LEVELER COMPONENTS

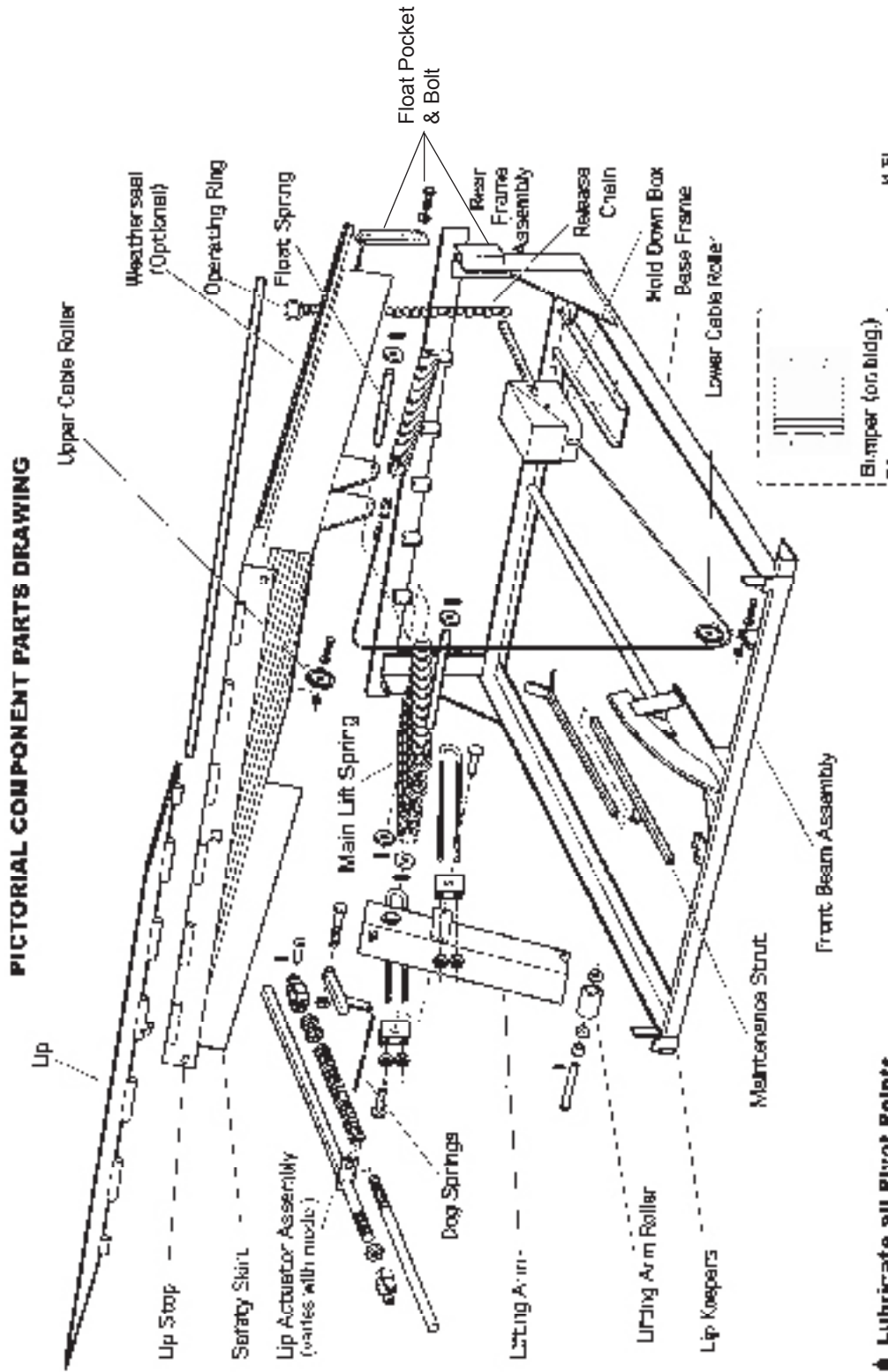

TROUBLE SHOOTING

Problem	Problem Cause
Deck does not raise	<ul style="list-style-type: none"> • Hold down mechanism not releasing. • Release chain, brake handle jammed or tension spring broken. • Foreign material lodged between side of deck and pit wall. • Damaged or missing bumpers allowing truck to contact and hold lip. • Lifting arm cam roller knocked off cam and jammed.
Deck does not raise fast quickly or smoothly	<ul style="list-style-type: none"> • Foreign material lodged in lip hinge, preventing full rotation. • Deck drag on side of pit, slowing deck. - Foreign material lodged between side of deck and pit wall. - Safety skirt damaged and dragging on pit wall (when used). - Out of square pit causing deck to drag on side of pit. • Lack of lubrication on lip hinge spools. • Lifting springs require adjustment. - Assure all other possible causes have been eliminated before changing spring adjustment.
Lip plate does reach the fully extended position	<p>Lip lock not engaging</p> <ul style="list-style-type: none"> • Broken or stretched lip lock springs. • Lip lock seized - not rotating into lock position
Deck will not 'Walk' down	<ul style="list-style-type: none"> • Foreign material in pit, blocking mechanism. • Side safety skirts badly damaged and jammed against pit wall (when used). • Lifting arm cam roller knocked off cam, causing lifting arm to jam against cam.
Deck is very hard to 'Walk' down	<ul style="list-style-type: none"> • Weather seals, skirts or deck dragging on pit wall. • Foreign material in pit. • Cam roller grooved badly by cam wear. • Cam roller bearing seized. • Lack of lubrication. • Lift springs adjusted improperly. - Tension has been mistakenly increased to overcome another problem.
Lip does not release and swing down when truck departs	<ul style="list-style-type: none"> • Lip lock seized. Does not swing down from locked position. - Lack of lubrication - Damaged by foreign material in pit. • Lip lock held in locked position by foreign material in pit.
Deck does not stay down. Springs back up after walking down	<ul style="list-style-type: none"> • Hold down cable broken. • Hold down cable is extended and intact, but does not rewind - Foreign material in hold down assembly stopping rotation of rewind wheel. - Cable rewind spring broken - Cable out of place and jammed in holddown box. • Cable rewinds into holddown box, but does not lock. - Pull chain or release lever jammed and not returning to locked position. - Foreign material lodged under release lever. - Lock roller, wear strip and rewind wheel locking surfaces worn from normal usage.
Lip strikes rear of truck as the deck raises, deck stops or slows down, and lip does not reach the extended position	<ul style="list-style-type: none"> • Damaged or missing dock bumpers allow the vehicle to be parked too close to the dock leveler. • Height differential between dock and transporter vehicle bed is greater than recommended. • Lip linkage damaged causing lip to begin extending too early in the cycle. • Lip linkage requires adjustment.
Lip will not clear rear of vehicle when attempting to return dock leveler to stored position with truck parked at dock	<ul style="list-style-type: none"> • Damaged or missing dock bumpers allow truck to be parked too close to the dock leveler. • Height differential between dock and transporter vehicle bed is greater than recommended. • Lip linkage damaged or jammed causing lip to be held out too late in cycle.
Dock bumper damage that is abnormal and excessive	<ul style="list-style-type: none"> • Shunting tractors with raise able fifth wheel damage bumpers by causing excess vertical movement of rear of trailer. • Air-ride suspension trailers can cause severe bumper damage if the trailer is raised against the bottom of or lowered on top of the bumper.
Deck drags on side wall of pit	<ul style="list-style-type: none"> • Pit/dock is out of square

GENERAL ASSEMBLY - 25, 30 & 35,000 LB. CAPACITY

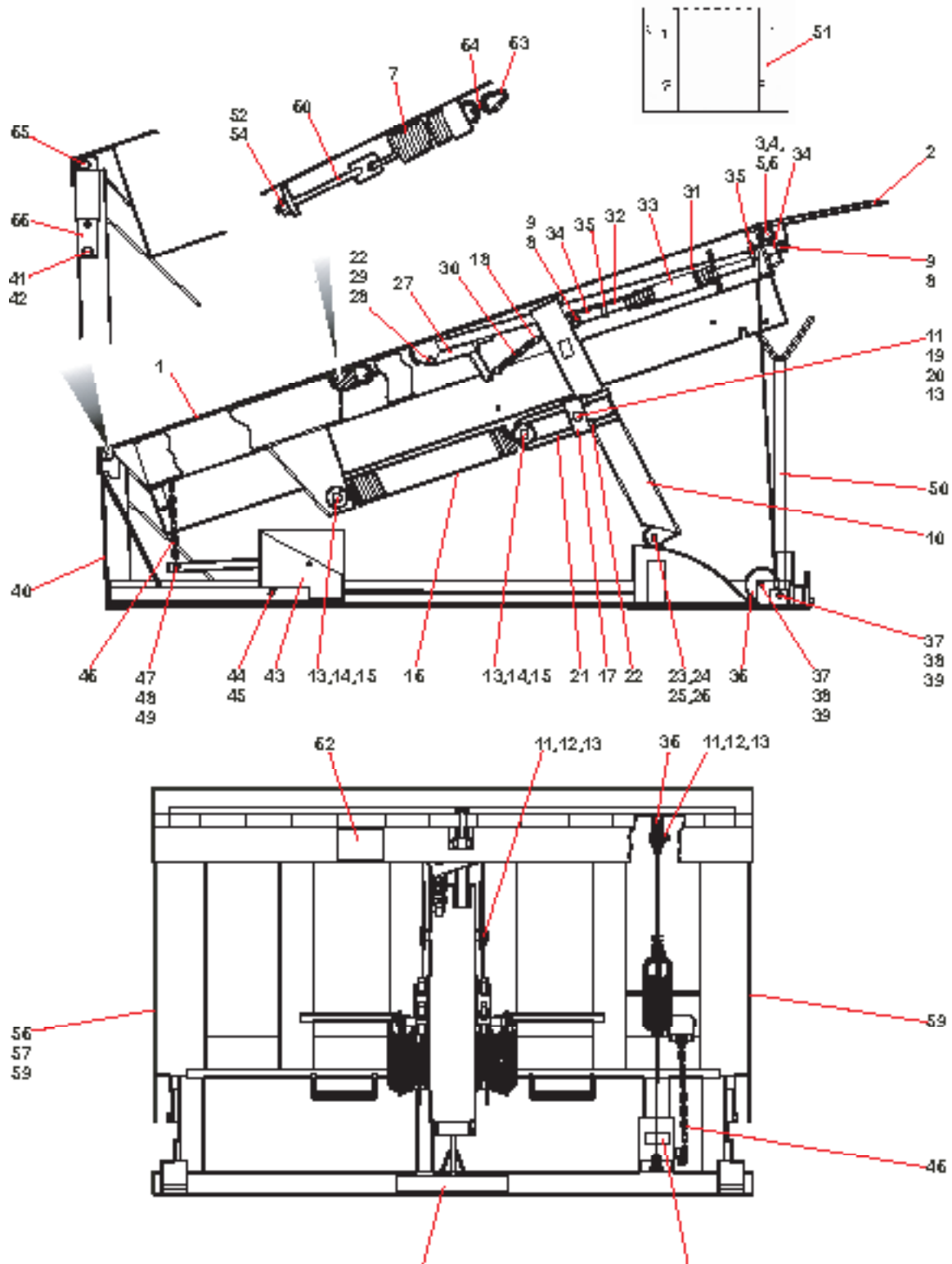

GENERAL ASSEMBLY - 25, 30 & 35,000 LB. CAPACITY

ITEM	QTY	PART NUMBER	GENERAL DESCRIPTION	SPECIFIC DESCRIPTION
				220-5001
1	1	785-692	Deck Weldment 6'wide 25# 6'lg	6'Wx6'L/25#
1	1	785-691	Deck Weldment 6'wide 25# 8'lg	6'Wx8'L/25#
1	1	222-5005	Deck Weldment 6'6"wide 25# 6'lg	6'6"Wx6'L/25#
1	1	222-5005-1	Deck Weldment 6'6"wide 25# 8'lg	6'6"Wx8'L/25#
1	1	222-5010	Deck Weldment 7'wide 25# 6'lg	7'Wx6'L/25#
1	1	222-5010-1	Deck Weldment 7'wide 25# 8'lg	7'Wx8'L/25#
1	1	222-5000	Deck Weldment 6'wide 30# 6'lg	6'Wx6'L/30#
1	1	222-5000-1	Deck Weldment 6'wide 30# 8'lg	6'Wx8'L/30#
1	1	222-5002	Deck Weldment 6'6"wide 30# 6'lg	6'6"Wx6'L/30#
1	1	222-5002-1	Deck Weldment 6'6"wide 30# 8'lg	6'6"Wx8'L/30#
1	1	222-5001	Deck Weldment 7'wide 30# 6'lg	7'Wx6'L/30#
1	1	222-5001-1	Deck Weldment 7'wide 30# 8'lg	7'Wx8'L/30#
1	1	222-5039	Deck Weldment 6'wide 35# 6'lg	6'Wx6'L/35#
1	1	222-5039-1	Deck Weldment 6'wide 35# 8'lg	6'Wx8'L/35#
1	1	222-5040	Deck Weldment 6'6"wide 35# 6'lg	6'6"Wx6'L/35#
1	1	222-5040-1	Deck Weldment 6'6"wide 35# 8'lg	6'6"Wx8'L/35#
1	1	222-5041	Deck Weldment 7'wide 35# 6'lg	7'Wx6'L/35#
1	1	222-5041 -1	Deck Weldment 7'wide 35# 8'lg	7'Wx8'L/35#
2	1	223-5022	Lip Widmt 16" 6' 1/2" Thk	6'Wx6'L/6'Wx8'L/25#
2	1	223-5020	Lip Widmt 16" 6'6" 1/2" Thk	6'6"Wx6'L/6'6"Wx8'L/25#
2	1	223-5021	Lip Widmt 16" 7' 1/2" Thk	7'Wx6'L/7'Wx8'L/25#
2	1	223-5017	Lip Widmt 16" 6' 1/2" Thk	6'Wx6'L/6'Wx8'L/30#
2	1	223-5019	Lip Widmt 16" 6'6" 1/2" Thk	6'6"Wx6'L/6'6"Wx8'L/30#
2	1	223-5018	Lip Widmt 16" 7' 1/2" Thk	7'Wx6'L/7'Wx8'L/30#
2	1	223-5016	Lip Widmt 16" 6' 1/2" Thk	6'Wx6'L/6'Wx8'L/35#
2	1	223-5012	Lip Widmt 16" 6'6" 1/2" Thk	6'6"Wx6'L/6'6"Wx8'L/35#
2	1	223-5001	Lip Widmt 16" 7' 1/2" Thk	7'Wx6'L/7'Wx8'L/35#
3	1	213-0005-1	Shaft, Lip 1"	6'Wx6'L/6'Wx8'L/25#
3	1	213-0005-2	Shaft, Lip 1"	6'6"Wx6'L/6'6"Wx8'L/25#
3	1	213-0005-3	Shaft, Lip 1"	7'Wx6'L/7'Wx8'L/25#
3	1	109-699	Shaft, Lip	6'Wx6'L/6'Wx8'L/30#/35#
3	1	109-687-1	Shaft, Lip	6'6"Wx6'L/6'6"Wx8'L/30#/35#
3	1	109-690	Shaft, Lip	7'Wx6'L/7'Wx8'L/30#/35#
4	2	010-037	Capscrew, Hex Hd. - 5/16"-18 X 3/4"	6',6'6",7'W/25#
5	2	011-502	Nut, Hex 5/16"-18	6',6'6",7'W/25#
6	2	012-200	Washer, Lock 5/16" Hel.	6',6'6",7'W/25#
7	1	203-0019	Float Spring	6',6'6",7'W/25#
8	2	107-196	Pin, Clevis	6',6'6",7'W/25#
9	2	013-010	Spring Pin, 1/4"X1-1/4 LG.	6',6'6",7'W/25#
10	1	223-5023	Arm, Lifting Weldm't (Mech 6')	6'L/25#
10	1	223-5023-1	Arm, Lifting Weldm't (Mech 8')	8'L/25#
11	6	018-501	Bearing Ball-Load Whl	6',6'6",7'W/25#
12	1	788-176	Lifting Arm Pin	6',6'6",7'W/25#
13	7	013-012	Spring Pin, 1/4"X2"	6',6'6",7'W/25#
14	2	113-122	Shaft, Mainspring Hanger	6'W/25#
14	2	109-137	Shaft, Mainspring Hanger	6'6" & 7'W/25#
15	4	012-250	Washer Flat, 1-1/16"ld X 2-1/2"Od	6'W/25#
15	4	012-216	Washer Flat, 1-5/16" BS	6'6" & 7'W/25#

GENERAL ASSEMBLY - 25, 30 & 35,000 LB. CAPACITY

ITEM	QTY	PART NUMBER	GENERAL DESCRIPTION	SPECIFIC DESCRIPTION
				220-5001
16	4	223-0004	Spring Dock Leveler Main	6'W/25#/30#/35#
16	5	223-0004	Spring Dock Leveler Main	6',6'6",7'W/25#/30#/35#
17	2	111-572	Adjusting Bracket	6',6'6",7'W/25#/30#/35#
18	4	013-134	Ring,Split Steel-Zinc .875"Dia	6',6'6",7'W/25#/30#/35#
19	2	788-085	U-Bolt Block Pin Assy	6',6'6",7'W/25#/30#/35#
20	2	105-879	3/16"X1/16"	6',6'6",7'W/25#/30#/35#
21	2	111-570	Adjustable U-Bolt	6',6'6",7'W/25#/30#/35#
22	5	011-510	Nut, Hex - 3/4"-10	6',6'6",7'W/25#/30#/35#
23	1	109-791	Lifting Arm Roller	6',6'6",7'W/25#/30#/35#
24	2	018-500	Bearing	6',6'6",7'W/25#/30#/35#
25	1	223-0000	Axle, Load Roller (4 3/4"Lg)	6',6'6",7'W/25#/30#/35#
26	1	013-011	Spring Pin 1/4"X1-3/8"	6',6'6",7'W/25#/30#/35#
27	1	793-965	Dog Assembly	6',6'6",7'W/25#/30#/35#
28	2	018-001	Bushing	6',6'6",7'W/25#/30#/35#
29	1	010-086	Capscrew, Hex Hd. 3/4"-10x3-1/4"	6',6'6",7'W/25#/30#/35#
30	1	109-107	Spring Extension	6',6'6",7'W/25#/30#/35#
31	1	793-375	Shock Absorber	6',6'6",7'W/25#/30#/35#
32	1	109-391	Lip Pusher Shaft	6',6'6",7'W/25#/30#/35#
33	1	223-0005	Compression Spring-Lip Assis	6',6'6",7'W/25#/30#/35#
34	1	114-663	Clevis (Machined)	6',6'6",7'W/25#/30#/35#
35	3	011-511	Nut, Hex Jam - 1"-8	6',6'6",7'W/25#/30#/35#
36	2	793-092	Cable Roller	6',6'6",7'W/25#/30#/35#
37	3	010-027	Capscrew, Hex Hd. 1/2"-13x2-1/2"	6',6'6",7'W/25#/30#/35#
38	3	012-274	Washer, 1-1/2"Odx.540"ID	6',6'6",7'W/25#/30#/35#
39	3	011-554	Nut, Hex 1/2"-13 Nylon Insert	6',6'6",7'W/25#/30#/35#
40	1	785-870	Frame Weld (6'w 6'lg 25#)	6'Wx6'L/25#
40	1	785-872	Frame Weld (6'w 8'lg 25#)	6'Wx8'L/25#
40	1	222-5006	Frame Weld (6'6"w 6'lg 25#)	6'6"Wx6'L/25#
40	1	222-5006-2	Frame Weld (6'6"w 8'lg 25#)	6'6"Wx8'L/25#
40	1	222-5007	Frame Weld (7"w 6'lg 25#)	7'Wx6'L/25#
40	1	222-5007-2	Frame Weld (7"w 8'lg 25#)	7'Wx8'L/25#
40	1	222-5033	Frame Weld (6'w 6'lg 30#)	6'Wx6'L/30#
40	1	222-5033-3	Frame Weld (6'w 8'lg 30#)	6'Wx8'L/30#
40	1	222-5034	Frame Weld (6'6"w 6'lg 30#)	6'6"Wx6'L/30#
40	1	222-5034-3	Frame Weld (6'6"w 8'lg 30#)	6'6"Wx8'L/30#
40	1	222-5035	Frame Weld (7"w 6'lg 30#)	7'Wx6'L/30#
40	1	222-5035-3	Frame Weld (7"w 8'lg 30#)	7'Wx8'L/30#
40	1	222-5033	Frame Weld (6'w 6'lg 35#)	6'Wx6'L/35#
40	1	222-5033-3	Frame Weld (6'w 8'lg 35#)	6'Wx8'L/35#
40	1	222-5034	Frame Weld (6'6"w 6'lg 35#)	6'6"Wx6'L/35#
40	1	222-5034-3	Frame Weld (6'6"w 8'lg 35#)	6'6"Wx8'L/35#
40	1	222-5035	Frame Weld (7"w 6'lg 35#)	7'Wx6'L/35#
40	1	222-5035-3	Frame Weld (7"w 8'lg 35#)	7'Wx8'L/35#
41	2	010-021	Capscrew, Hex Hd. 1/2"-13x3/4"	6',6'6",7'W/25#/30#/35#
42	2	012-230	Washer, Lock-1/2" Int. Tooth	6',6'6",7'W/25#/30#/35#
43	1	788-037-2	Hold Down Box General Assy	6',6'6",7'W/25#/30#/35#
44	1	113-081	Hold Down Box Pin (Mdl)	6',6'6",7'W/25#/30#/35#

GENERAL ASSEMBLY - 25, 30 & 35,000 LB CAPACITY

ITEM	QTY	PART NUMBER	GENERAL DESCRIPTION	SPECIFIC DESCRIPTION
				220-5001
45	2	013-018	Cotter Pin 3/32"X1"	6',6'6",7"W/25#/30#/35#
46	1	788-197	Pull Chain Assembly	6',6'6",7"W/25#/30#/35#
47	1	010-007	Capscrew, Hex Hd. 5/16"-18x1-1/2"	6',6'6",7"W/25#/30#/35#
48	1	011-543	Nut, Hex-5/16"-18 Nylon Insert	6',6'6",7"W/25#/30#/35#
49	1	012-211	Washer, Flat 5/16" Bs	6',6'6",7"W/25#/30#/35#
50	1	200-5001	Safety Strut Ass'y	6',6'6",7"W/25#/30#/35#
51	2	DB411	Laminated Bumper 4.5" D x 14" W x 10" H	6',6'6",7"W/25#/30#/35#
52	2	012-213	Washer, Flat 5/8" Bs	6',6'6",7"W/25#/30#/35#
53	1	010-101	Capscrew, 5/8"-11x3"	6',6'6",7"W/25#/30#/35#
54	1	011-509	Nut, Hex 5/8"-11	6',6'6",7"W/25#/30#/35#
55	1GA	039-066	Paint, Blue (Fast Dry Enamel)	6',6'6",7"W/25#/30#/35#
56	1	108-120	Serial Number Plate	6',6'6",7"W/25#/30#/35#
57	4	011-083	Tack (Rivet)	6',6'6",7"W/25#/30#/35#
58	1	038-196	Decal Blue Giant	6',6'6",7"W/25#/30#/35#
59	1	038-010	Decal, Safety Stripe Black/Yellow	6',6'6",7"W/25#/30#/35#
60	1	223-5026	Spring Rod	6',6'6",7"W/25#/30#/35#
61	1	038-048-2	Decal, Warning	6',6'6",7"W/25#/30#/35#
62	1	832-317	Label, Warning "Do Not Work..."	6',6'6",7"W/25#/30#/35#
63	1	013-522	Thimble, Cable	6',6'6",7"W/25#/30#/35#
64	1	222-5097	Spring Connection Plate	6',6'6",7"W/25#/30#/35#
65	1	100-453	Pin, Deck Hinge	6'W/25#/30#/35#
65	1	113-643	Pin, Deck Hinge	6'6"W/25#/30#/35#
65	1	109-363	Pin, Deck Hinge	7'W/25#/30#/35#
66	2	113-043	Bar, Tilt	6',6'6",7"W/25#/30#/35#

HOLDOWN GENERAL ASSEMBLY

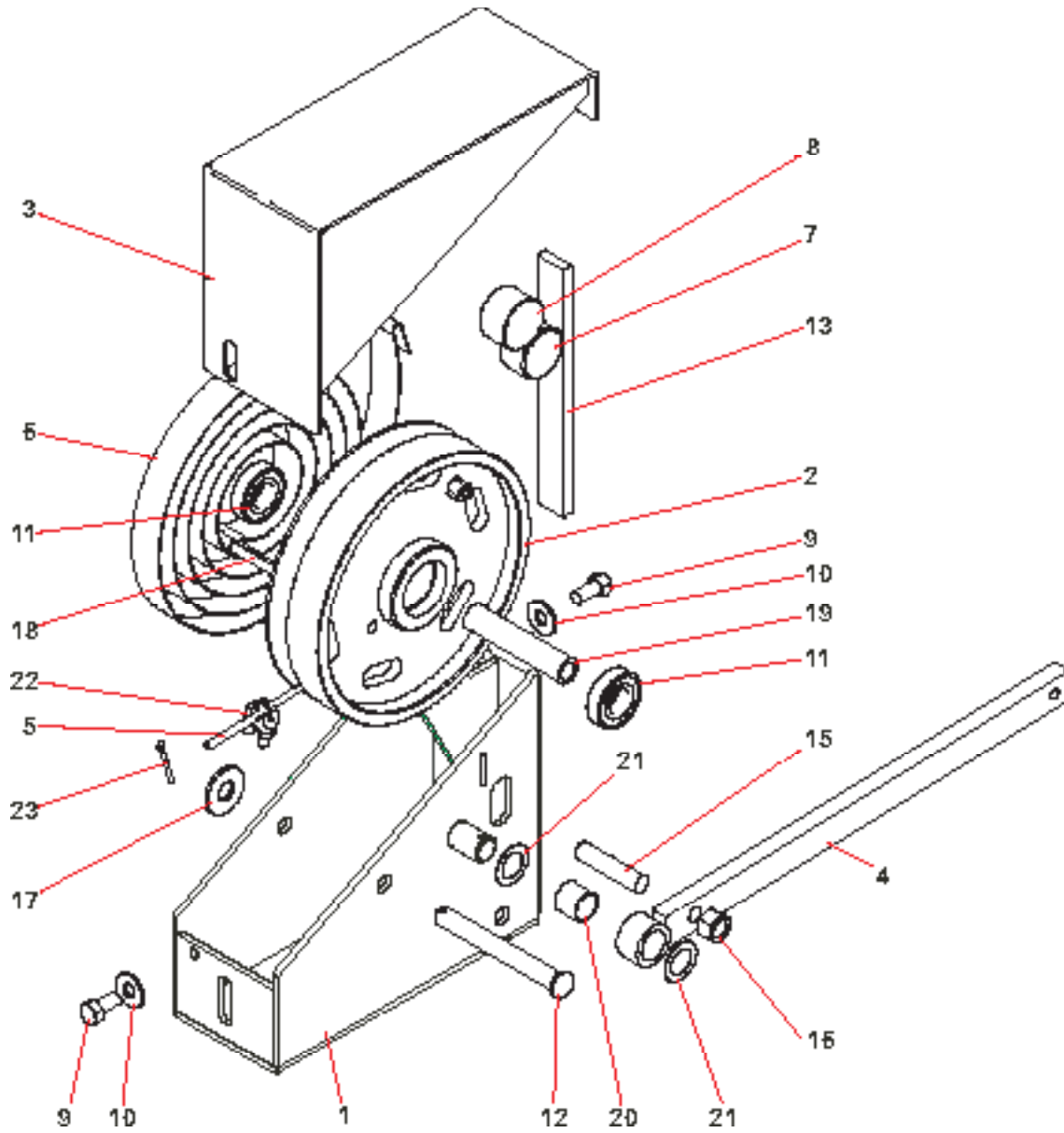

HOLDOWN GENERAL ASSEMBLY

ITEM	QTY	PART NUMBER	GENERAL DESCRIPTION	SPECIFIC DESCRIPTION
-----	-----	788-037-2	Assembly, Hold Down Box	783-037-2
1	1	788-035	Hold Down Box Weldment	All Models
2	1	788-111-2	Rewind Whl. For 1/4" Cable	All Models
3	1	788-034	Hold Down Box Cover	All Models
4	1	788-055	Release Control Assy (Mdl)	All Models
5	1	223-0017	Cable Assy, Hold Down 6/8/10'	All Models
6	1	113-143	Coil Spring	All Models
7	1	103-167	Lock Roller (Hardened)	All Models
8	1	113-085	Counter Weight	All Models
9	2	010-012	Capscrew, Hex Hd. 3/8"-16x3/4"	All Models
10	2	012-210	Washer, Flat - 1/4" Bolt S	All Models
11	2	018-500	Bearing	All Models
12	1	210-0005	Pin (4.5") Zinc Plated	All Models
13	1	113-089	Wear Strip	All Models
14	1	013-005	Spring Pin 5/32"X1"Lg	All Models
15	1	113-090	Stud	All Models
16	1	011-508	Nut, Hex 1/2"-13	All Models
17	1	012-239	Washer, Spacer-0.501/0.505 Idx1"Odx1/8"THK	All Models
18	1	013-094	Spring Pin - 5/16"X2-1/2"LG	All Models
19	1	113-198	Rewind Wheel Sleeve	All Models
20	1	018-001	Bushing	All Models
21	2	105-878	Washer	All Models
22	1	013-536	Clamp-1/4" Dia Cable	All Models
23	1	013-021	Cotter Pin-1/8"X1-1/4"	All Models

SAFETY SKIRTS GENERAL ASSEMBLY

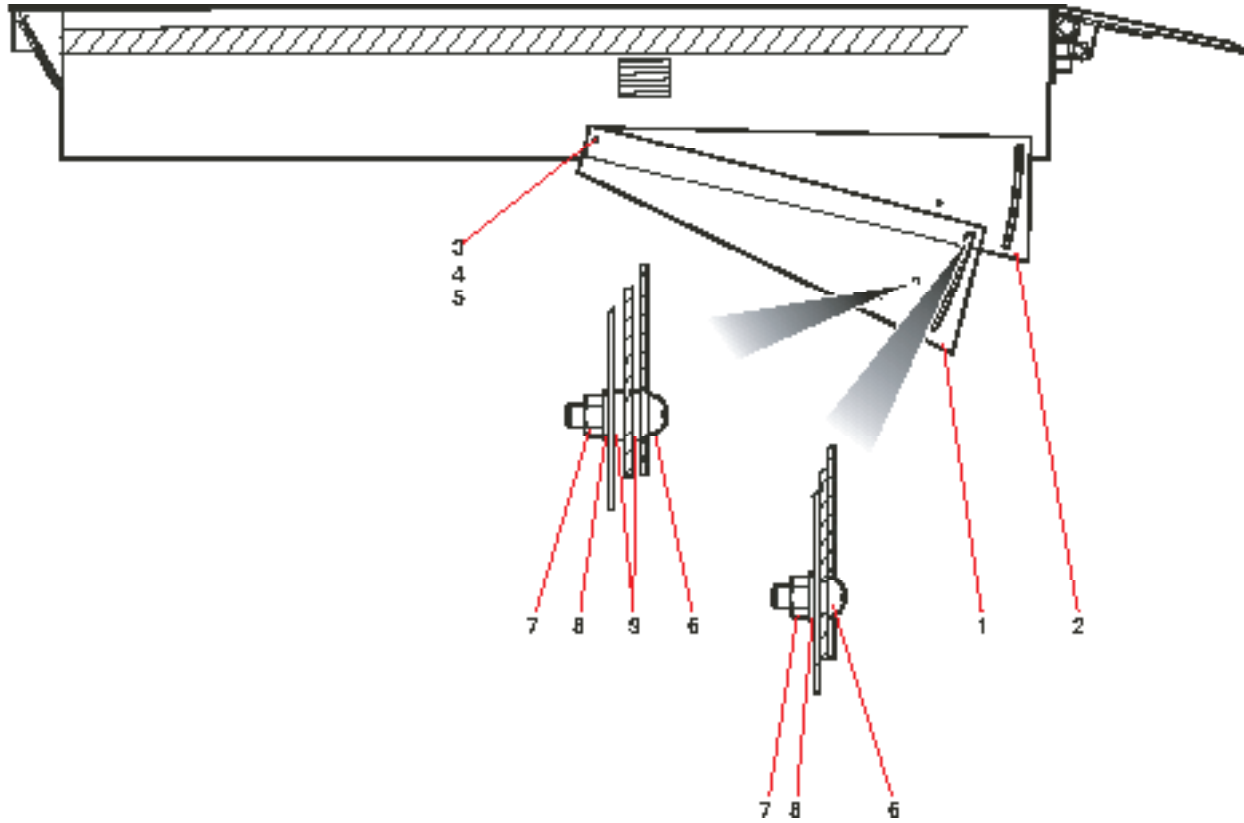

SAFETY SKIRT GENERAL ASSEMBLY

ITEM	QTY	PART NUMBER	GENERAL DESCRIPTION	SPECIFIC DESCRIPTION
-----	-----	202-5024	Safety Skirt Package	6 & 8' Long
-----	-----	202-5024-1	Safety Skirt Package	10' Long
-----	-----	202-5024-2	Safety Skirt Package	12' Long
1	2	202-0036	Safety Skirt, Lower	6 & 8' Long
1	2	202-5036-1	Safety Skirt, Lower	10' Long
1	2	202-5035	Safety Skirt, Lower	12' Long
2	2	202-0037	Middle Safety Skirt	6 & 8' Long
2	2	202-5037-1	Middle Safety Skirt	10' & 12' Long
3	2	010-039	Cap Screw, Hex Hd. - 3/8"-16x1"	All Models
4	2	012-252	Washer, Flat -3/8"ID BS Washer	All Models
5	2	011-552	Nut, Hex 3/8"-16 Nylon Insert	All Models
6	4	011-135	Capscrew, Sckt Butn/Hd 5/16"-18x3/4"	All Models
7	4	011-543	Nut, Hex - 5/16"-18 Nylon Insert	All Models
8	4	012-211	Washer, Zinc 5/16" Bs Flat	All Models
9	4	012-312	Washer Nylon Fender 5/16"IDx 7/8"ODx1/16"TH	All Models
10	2 GA	039-059	Paint, Safety Yellow	All Models

WARRANTY

MECHANICAL DOCK LEVELER

The Manufacturer's Base Warranty covers the following Product Classes, each of which is covered under additional warranties (if applicable) specific to each class.

Mechanical Dock Leveler

BASE WARRANTY

The manufacturer warrants to the original purchaser its loading dock equipment to be free from defective material and workmanship under normal use for a period of 1 year (365 days). All warranty coverage is to commence from the date of receipt by the first user or sixty (60) days after date of shipment, whichever comes first. The said equipment must be properly installed, operated and maintained by trained personnel, and must be operated in compliance with the manufacturer's recommendations with regards to rated capacities, duty cycle limitations, grade limitations and/or design specific application(s) agreed upon at the point of sale.

Initial field set up, adjustment, lubrication and other maintenance are not covered under this warranty and are the sole responsibility of the installer and / or end user. The Warranty Registration Form must be completed in full and returned to the manufacturer within sixty (60) days of receipt in order for the warranty to be deemed valid.

The manufacturer shall remedy any defects deemed covered under this warranty by replacing or repairing any equipment or parts while incurring reasonable expenses for all parts, labor and freight unless otherwise stated herein. Freight expenses for shipping repair/replacement parts will be incurred under conditions of standard shipping terms. Any overnight or special freight requirements will be billed to the end user or authorized dealer as determined by the manufacturer.

Any Original Equipment Manufactured (OEM) part that is replaced during the Base Warranty time period will be either: further covered for the remainder of the Base Warranty time period, or for a further 90 days: whichever is longer.

ADDITIONAL WARRANTY TIME PERIODS:

Parts or components which fail under normal usage and are proven to be defective will be deemed eligible for repair or replacement, (providing no special conditions apply, as stated below) providing the failure occurs within the Additional Warranty Time Period of a given Product Class as stated below. Replacement parts will be supplied F.O.B. factory.

Mechanical Dock Leveler

Structural - Covered for an additional four (4) years following expiration of the Base Warranty time period.

Components include: Deck, frame, support beams, lip and hinge. Freight is covered under the Base Warranty time period only.

Main Lift Springs - Covered for an additional four (4) years following expiration of the Base Warranty time period - Parts only. Labor and freight are covered under the Base Warranty time period only.

Parts and Labor: No further coverage beyond the Base Warranty time period for any components (including Options) not listed above.

WARRANTY IS VOID IF:

- 1) Warranty Registration Form is not fully completed and returned to the manufacturer within sixty (60) days of receipt.
- 2) The original purchaser does not notify the manufacturer of the defect within ninety (90) days after the defect has been identified.
- 3) Equipment is modified in any manner not approved in writing by the manufacturer.
- 4) Equipment has been operated:
 - beyond its rated capacity,
 - in excess of its determined duty cycle,
 - or operated in excess of its determined maximum grade,
 - or combination of the above therein, which can directly be attributed to be the cause of failure.
- 5) Equipment is used in abrasive or corrosive conditions, or conditions of excessive cold or moisture without having been factory specified to be engineered to withstand such conditions.

THE FOLLOWING ARE NOT COVERED UNDER WARRANTY:

- 1) Adjustments, including initial field set-up. Adjustments are considered part of normal maintenance procedures.
- 2) Repairs required as a result of:
 - Failure to follow maintenance and/or lubrication procedures specified in the owner's manual.
 - Abuse, willful damage, accident, or neglect.
 - Shipping damage. (Claim must be made with the freight carrier.)

THE MANUFACTURER DOES NOT ASSUME RESPONSIBILITY OR LIABILITY FOR INCIDENTAL, CONSEQUENTIAL OR SPECIAL DAMAGES, OR FOR LOSS OF PROFIT OR DAMAGE TO TRADE OR BUSINESS WHICH RESULTS FROM THE EQUIPMENT.

THE ABOVE WARRANTIES ARE IN LIEU OF ANY OTHER WARRANTIES, EITHER EXPRESSED OR IMPLIED, INCLUDING BUT NOT LIMITED TO ANY IMPLIED WARRANTY OF MERCHANTABILITY OR FITNESS FOR A PARTICULAR PURPOSE. THERE ARE NO WARRANTIES WHICH EXTEND BEYOND THE DESCRIPTION CONTAINED HEREIN.

NOTES:

NOTES:



88 Heart Lake Road South
Brampton, Ontario, Canada L6W 3C2
Phone: 905 457 3500 • Fax: 905 457 2313
www.BlueGiant.com

BLUE GIANT EQUIPMENT CORPORATION